



**Commercial Fridge
& Freezer Sales
Australia**

SALAD TABLE - BUFFET REFRIGERATOR
MODEL : KSR9-1



- Pans not included.

FEATURES / BENEFITS

HOT GAS CONDENSATE SYSTEM

Through Turbo Air's creative innovation, the condensate system surfaces have been specially treated to resist corrosion. This not only increases efficiency without the risk of refrigerant leakage from corrosion, but also prevents the overflow of condensate water.

SIDE MOUNT COMPRESSOR UNIT

By positioning the compressor on the side of the unit, refrigerators can now be serviced without being moved. Our innovative, front breathing feature also allows this model to provide high efficiency in narrow spaces.

EFFICIENT REFRIGERATION SYSTEM

Turbo Air's solid door refrigerators are designed with oversized and balanced refrigeration systems. These include efficient evaporators and condensers for faster cooling and greater efficiency.

EXTERIOR & INTERIOR OF THE CABINET

The Turbo Air K series boasts a stainless steel exterior (galvanized steel back and bottom). Interior is stainless steel floor with AL sides, back and AL door liners. It guarantees the utmost in cleanliness and long product life. It can add a touch of style to the most refined setting.

HIGH-DENSITY POLYURETHANE INSULATION

The entire cabinet structure and solid doors are foamed-in-place using high density, CFC free polyurethane insulation.

MAGNETIC DOOR GASKETS

Magnetic door gaskets are of one piece construction, removable without tools for ease of cleaning and replacement.

ADJUSTABLE, HEAVY DUTY, PE (POLYETHYLENE) COATED WIRE SHELVES

ERGONOMICALLY DESIGNED DOORS

Customers' fatigue fades away with easy grip handles and doors that open effortlessly. These features along with self-closing doors make this the ultimate choice in customer convenience.

Model	Swing Door	Capacity (litres)	#of Shelves	HP	AMPS	Crated Weight (kg)	W x D x H (mm)
KSR9-1	1	213	1	1/4	2.3	70	900 x 700 x 850

Ver.DEC.2015



SALAD TABLE - BUFFET

REFRIGERATOR
MODEL : KSR9-1

Model : KSR9-1

SPEC SHEET	KSR9-1
Classification	Refrigerator
Cabinet dimension (WxDxH mm)	900x700x850
Capacity (Liters)	213
Inner Temperature	1°C ~ 8°C
Ambient Temperature	40°C
Doors	1
# of shelves	1
Refrigerant	R-134a
Compressor (HP)	1/4
Cooling Type	Fan cooling type
Insulation Type	Polyurethane/ Cyclopentane+CFC Free
Temperature Control Type	Digital
Amps (A)	2.3
Voltage (V/Hz/Ph)	240V 50Hz 1Ph
Power (W)	314
Weight (Kg)	70

Design and specifications subject to change without notice.
Actual shipping weight may differ due to extra packing materials for product protection.

- DOOR LOCKS STANDARD
- INTERIOR LED LIGHTING STANDARD
- SELF-CONTAINED SYSTEM
- STANDARD 4" SWIVEL CASTERS WITH LOCKS ON THE FRONT SET

WARRANTY **2 YEARS**
PARTS & LABOUR

Ver.DEC.2015

PLAN VIEW

(unit : mm)

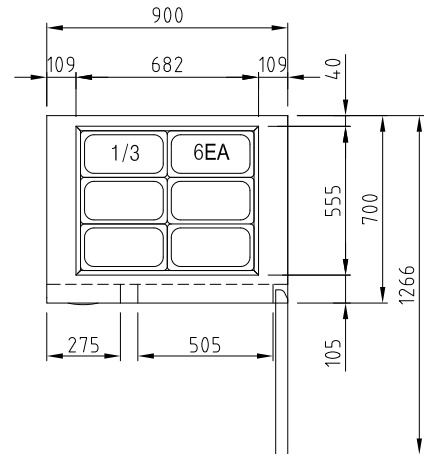

PLAN VIEW

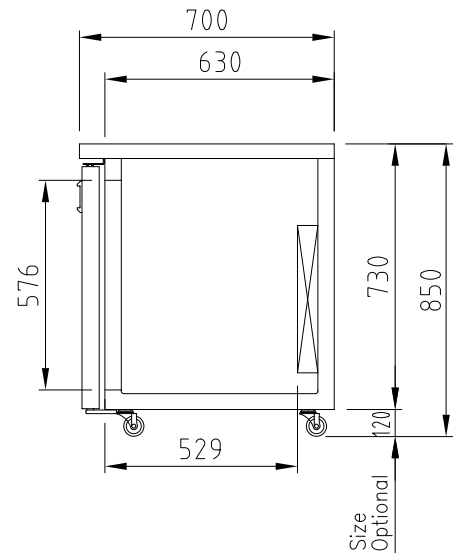

SIDE VIEW



Commercial Fridge & Freezer Sales Australia Pty Ltd
PO Box 455 East Melbourne VIC 8002 Australia
Tel: 1300 733 715 | Email: admin@commercialfridgefreezer.com.au
www.commercialfridgefreezer.com.au

REFRIGERATOR MANUFACTURER
Turbo air

Austune
1800 FRIDGE

