

GLASS DOOR MERCHANDAISER

REFRIGERATOR
MODEL : TGM-47SD

FEATURES / BENEFITS

■ HOT GAS CONDENSATE SYSTEM

Through Turbo Air's creative innovation, the condensate system surfaces have been specially treated to resist corrosion. This not only increases efficiency without the risk of refrigerant leakage from corrosion, but also prevents the overflow of condensate water.

■ ENERGY CONSERVING FAN CONTROL

Utilizing algorithmic air circulation for optimal temperature levels, our innovative fan control system conserves energy by at least 15% and increases compressor life by up to 30%.

■ LED LIGHTING INTERIOR DISPLAY SYSTEM

Brighter and longer lasting LED lights provide attractive, enhanced illumination compared to fluorescents. It saves energy by producing less heat, while maximizing the visibility in the display area.

■ MODERN DESIGN

By harmonizing curvature and rigidness, our modern style product designs are user-friendly while maintaining the highest product visibility and aesthetics.

■ DOOR OPENING ALARM

If the doors are not tightly closed, the refrigerator will not run. This would cause the cold air to escape through the opening, making food products spoil inside the cabinet. To prevent this problem, our refrigerators are equipped with the Door Alarm System that will sound if the doors are left open for more than 30 seconds.

■ EARLY WARNING SYSTEM

Malfunctions are generally recognized when an increase in temperature is detected, 2 to 3 hours after the refrigerator had stopped running. This causes the user to become aware of malfunction issues the next morning in which the contents may have already spoiled. To eliminate this, Turbo Air units have a warning system in place that diagnoses and monitors itself for risk factors, which gives an early warning signal in the form of an audible alarm to eliminate product loss and future service issues.

■ SHADOW FREE ADVERTISING PANEL

Turbo Air is the pioneer in the refrigerator industry on applying special LED Light Guided Panels (LGP). LGP increases panel visibility and eliminates shadows, thus enhances any store atmosphere with eye-catching effects. LED lighting offers 10 times longer lasting life than fluorescents and conserves energy as well.

■ DIGITAL TEMPERATURE CONTROL SYSTEM

Digital technology provides precise and constant temperatures throughout the cabinet. This allows food products to remain fresh over an extended period of time.



TGM-47SDB



TGM-47SDW

Model	Swing Door	Capacity (litres)	#of Shelves	HP	AMPS	Crated Weight (kg)	W x D x H (mm)
TGM-47SD	2	1308	8	1/3	3.1	196	1299 x 809 x 2136

GLASS DOOR MERCHANDAISER

REFRIGERATOR
MODEL : TGM-47SD

Model :TGM-47SD

PLAN VIEW

(unit : mm)

SPEC SHEET	TGM-47SD
Classification	Refrigerator
Cabinet dimension (WxDxH mm)	1299x809x2136
Capacity (Liters)	1308
Inner Temperature	0°C ~ 8°C
Ambient Temperature	40°C
Doors	2
# of shelves	8
Refrigerant	R-134a
Compressor (HP)	1/3
Cooling Type	Fan cooling type
Insulation Type	Polyurethane/ Cyclopentane+CFC Free
Temperature Control Type	Digital
Amps (A)	3.1
Voltage (V/Hz/Ph)	240V 50Hz 1Ph
Power (W)	620
Weight (Kg)	196

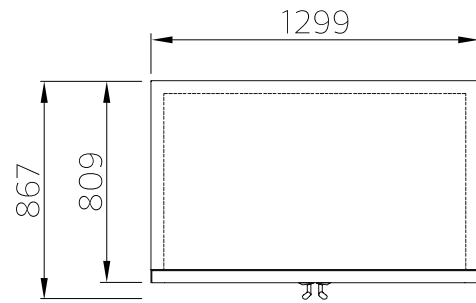

TOP VIEW

Design and specifications subject to change without notice.
Actual shipping weight may differ due to extra packing materials for product protection.

- **TWO COLOR OPTIONS AVAILABLE (STANDARD)**
Super Deluxe series comes in white cabinet (W) or black cabinet with black color trim (B).
- **DOOR LOCKING SYSTEM STANDARD**
- **LOW-E DOUBLE GLASS STANDARD**
- **4" SWIVEL CASTERS STANDARD**

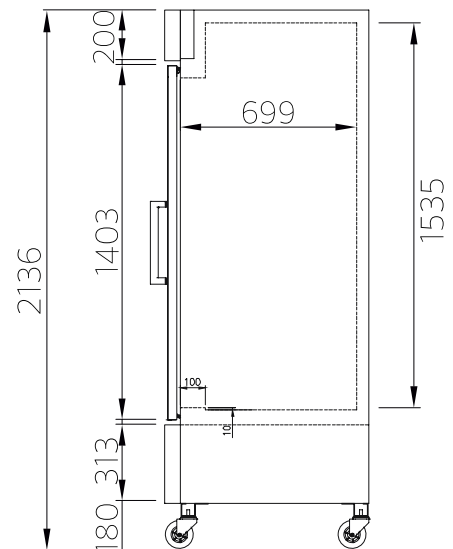

SIDE VIEW

WARRANTY **2 YEARS**
PARTS & LABOUR



Turbo air

